

KombiSIGN 50 / Accessories
Bracket for KS50 BK



Part No.: 975.845.02

MECHANICAL DATA	
Length	50 mm
Width	52 mm
Height	56 mm
Diameter	27 mm
Materials	PA-GF
Housing colour	Black
Weight with packaging	30 g
Product weight	30 g

APPROVAL DATA	
WEEE	No
Conforms with RED directive	No
Conforms with ATEX-directive	No
Conforms with CCC	No
Conforms with UL	No
Conforms with FCC	No
Conforms with IC	No
EAC certificate available	No
Conforms with AS-I	No
ICAO Certification	No
Conforms with DNV	No
Conforms with RoHS CN	No



For additional installation and mounting information, refer to the appropriate user guide at www.werma.com. This printed copy is for information only and is subject to alteration.

KombiSIGN 50 / Accessories

Bracket for KS50 BK

DRAWING

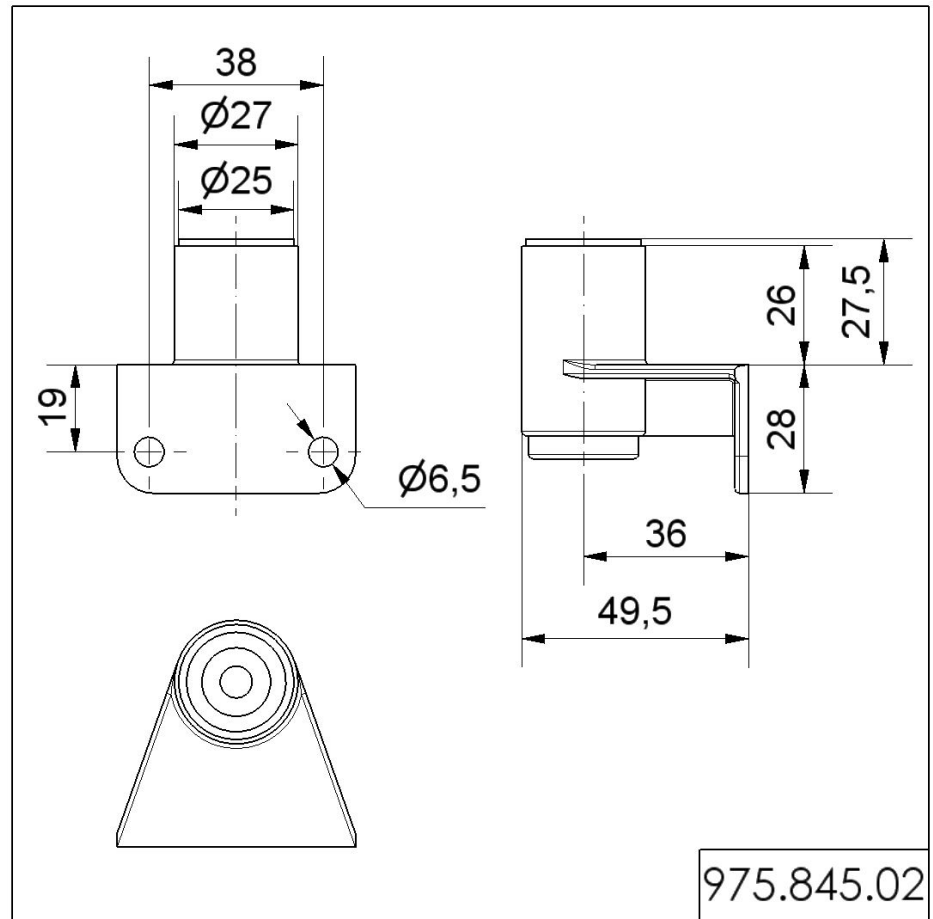

! For additional installation and mounting information, refer to the appropriate user guide at www.werma.com. This printed copy is for information only and is subject to alteration.